



SITE PLAN

INTRAUrBAN SOUTHLANDS

BUILDING 1



BUILDING 2

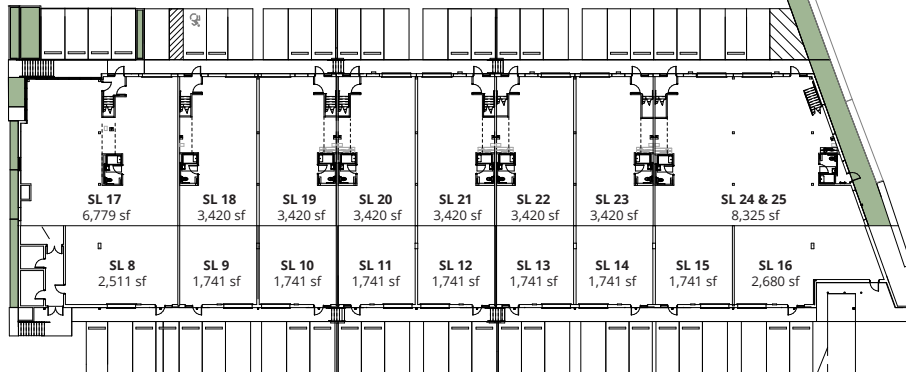

BUILDING 3

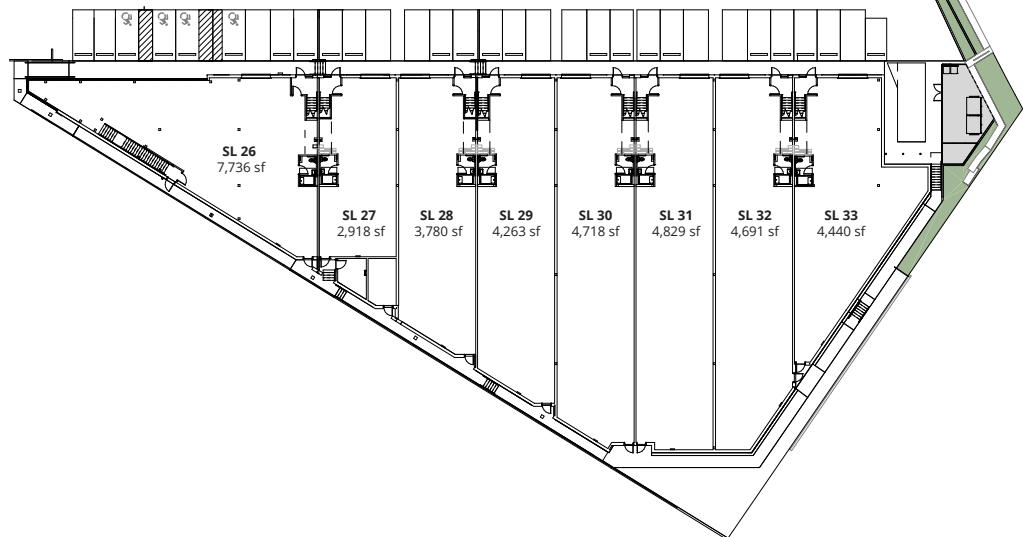

INTRAUrBAN.ca/SOUTHLANDS





BUILDING 2 PRICING

INTRAURBAN SOUTHLANDS

LOWER LEVEL

8698 BARNARD STREET,
VANCOUVER

JUNE 2023



Strata Lot	Total (sf)	Price (psf)	Total Price
SL 8	2,511	\$795	\$1,996,245
SL 9	1,741	\$785	\$1,366,685
SL 10	1,741	\$785	\$1,366,685
SL 11	1,741	\$780	\$1,357,980
SL 12	1,741	\$780	\$1,357,980
SL 13	1,741	\$780	\$1,357,980
SL 14	1,741	\$780	\$1,357,980
SL 15	1,741	\$775	\$1,349,275
SL 16	2,680	\$775	\$2,077,000
Total	17,378		

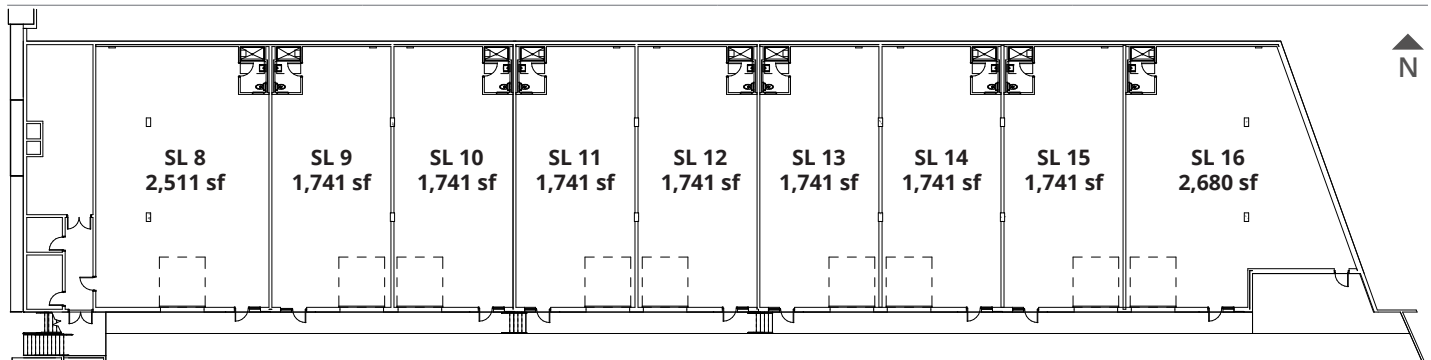

INTRAURBAN.CA/SOUTHLANDS



© 2023 Avison Young. All rights reserved. E. & O.E.: The information contained herein was obtained from sources that we deem reliable and, while thought to be correct, is not guaranteed Avison Young Commercial Real Estate Services, LP ("Avison Young")

All materials, measurements, specifications, renderings and layouts are preliminary and displayed for illustrative purposes only. The information contained herein is subject to change at any time without notice.



BUILDING 2 PRICING

INTRAUrBAN SOUTHLANDS

GROUND FLOOR & MEZZANINE

8698 BARNARD STREET,
VANCOUVER

JUNE 2023



Strata Lot	Ground Floor (sf)	Mezzanine (sf)	Total (sf)	Price (psf)	Total Price
SL 17	4,616	2,163	6,779	\$850	\$5,762,150
SL 18	2,315	1,105	3,420	\$840	\$2,872,800
SL 19	2,315	1,105	3,420	\$840	\$2,872,800
SL 20	2,315	1,105	3,420	\$830	\$2,838,600
SL 21	2,315	1,105	3,420	\$830	\$2,838,600
SL 22	2,315	1,105	3,420	\$830	\$2,838,600
SL 23	2,315	1,105	3,420	\$820	\$2,804,400
SL 24 & 25	5,854	2,471	8,325	\$820	\$6,826,500
Total	24,360	11,264	35,624		

[INTRAUrBAN.ca/SOUTHLANDS](https://www.intraurban.ca/southlands)





BUILDING 2

INTRAURBAN SOUTHLANDS

GROUND FLOOR

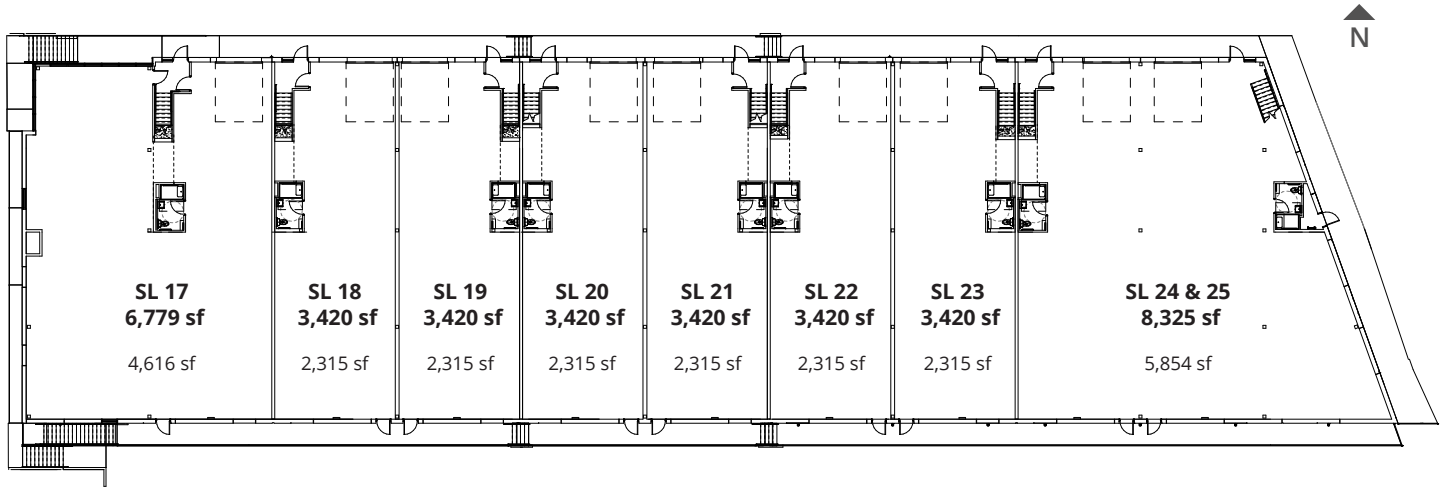

MEZZANINE

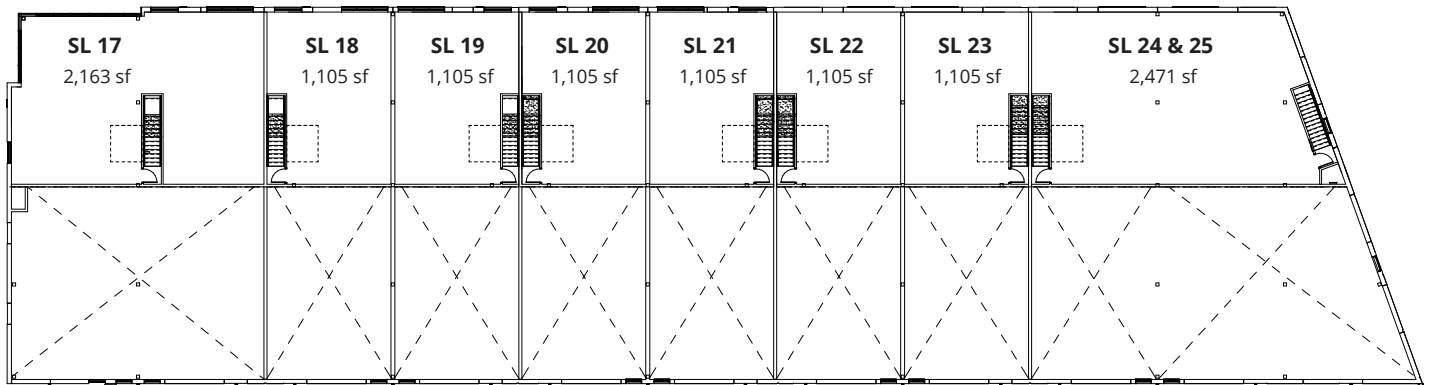

[INTRAURBAN.CA/SOUTHLANDS](https://www.intraurban.ca/southlands)





BUILDING 3 PRICING

INTRAUrBAN SOUTHLANDS

GROUND FLOOR & MEZZANINE

8710 BARNARD STREET,
VANCOUVER

JUNE 2023



Strata Lot	Ground Floor (sf)	Mezzanine (sf)	Total (sf)	Price (psf)	Total Price
SL 26	3,862	3,874	7,736	\$850	\$6,575,600
SL 27	1,813	1,105	2,918	\$840	\$2,451,120
SL 28	2,675	1,105	3,780	\$840	\$3,175,200
SL 29	3,158	1,105	4,263	\$830	\$3,538,290
SL 30	3,613	1,105	4,718	\$830	\$3,915,940
SL 31	3,724	1,105	4,829	\$830	\$4,008,070
SL 32	3,586	1,105	4,691	\$820	\$3,846,620
SL 33	3,171	1,269	4,440	\$820	\$3,640,800
Total	25,602	11,773	37,375		

[INTRAUrBAN.ca/SOUTHLANDS](https://www.intraurban.ca/southlands)



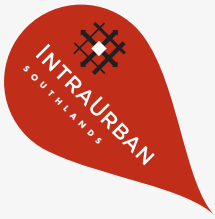

BUILDING 3

INTRAUrBAN SOUTHLANDS

GROUND FLOOR

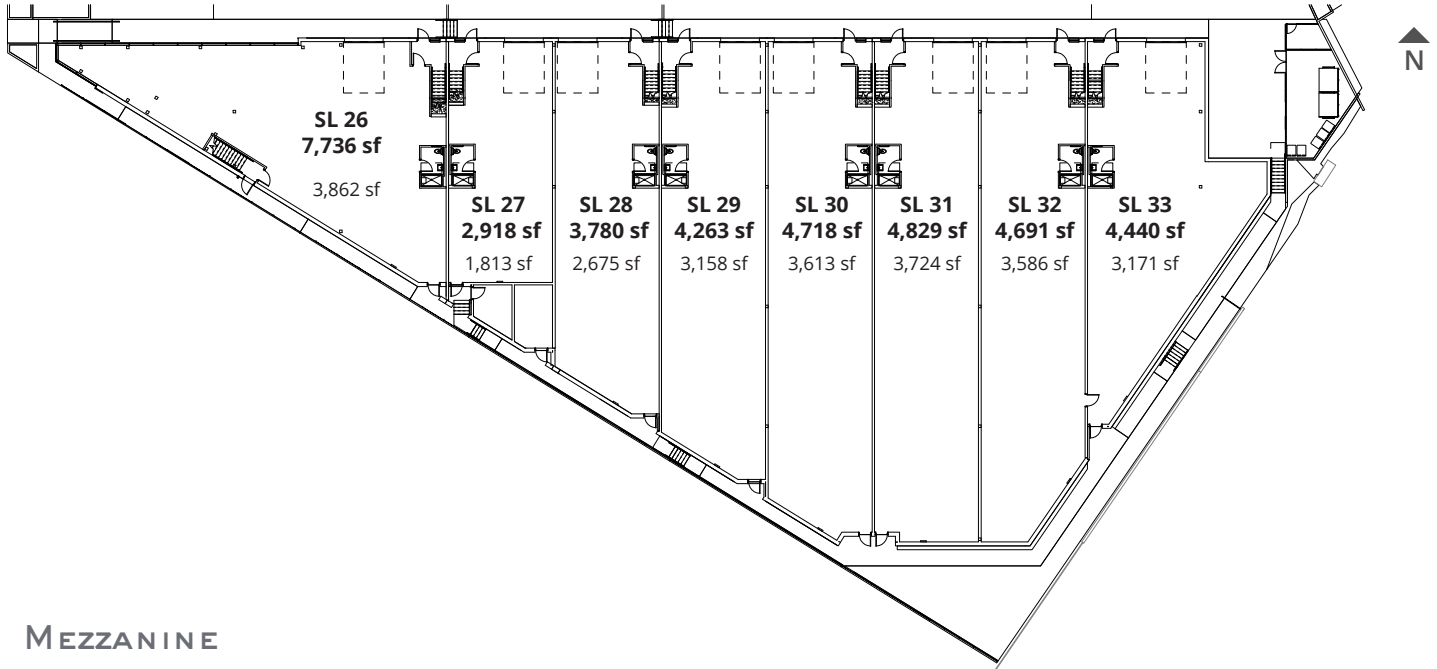

MEZZANINE

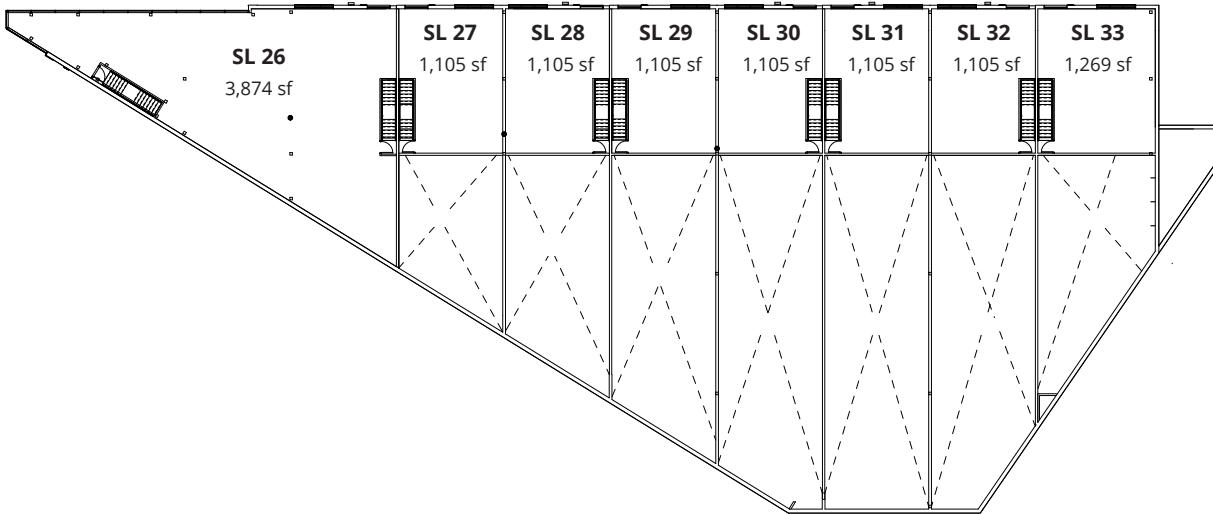

INTRAUrBAN.ca/SOUTHLANDS

